

## INSTRUCTIONS FOR INSTALLATION AND USE OF CONTROL UNIT EP096AD

# *Multi-Pull*

### 1. GENERAL INFORMATION

The "EP096AD" Display allows a shooting range to be run, in a fully automatic way, in the overall sporting disciplines suitable today.

This unit is a display that represent the next shot, with some letters or label.

For Compak Sporting:

The letters starts from A for trap exit no. 1, B for trap exit no. 2, etc...

When the microphone is active the display is blinking to advice the shooter.

In case of a double shot 2 leds will inform the shooter also about the type of double: immediate or on-report.

The last led will inform the shooter when he have to move to the next stand

For Other disciplines the display will indicate when the microphone is active with an "OK" or for skeet with type of trap: "P" for Pull, "M" for Mark.

The display can be installed on a tripod model EP096AT to replace the existing lamp, without additional wires

### 2. TECHNICAL CHARACTERISTICS OF THE UNIT

|                              |             |
|------------------------------|-------------|
| Power:                       | 12v dc      |
| Operating temperature range: | 0°C ÷ +45°C |
| Total weight:                | 0.3 Kg.     |

### 3. INSTALLATION

Open the box where of the display and identify the small holes where the wires must be connected.

With a welder connect the wires coming from the plug like in the picture

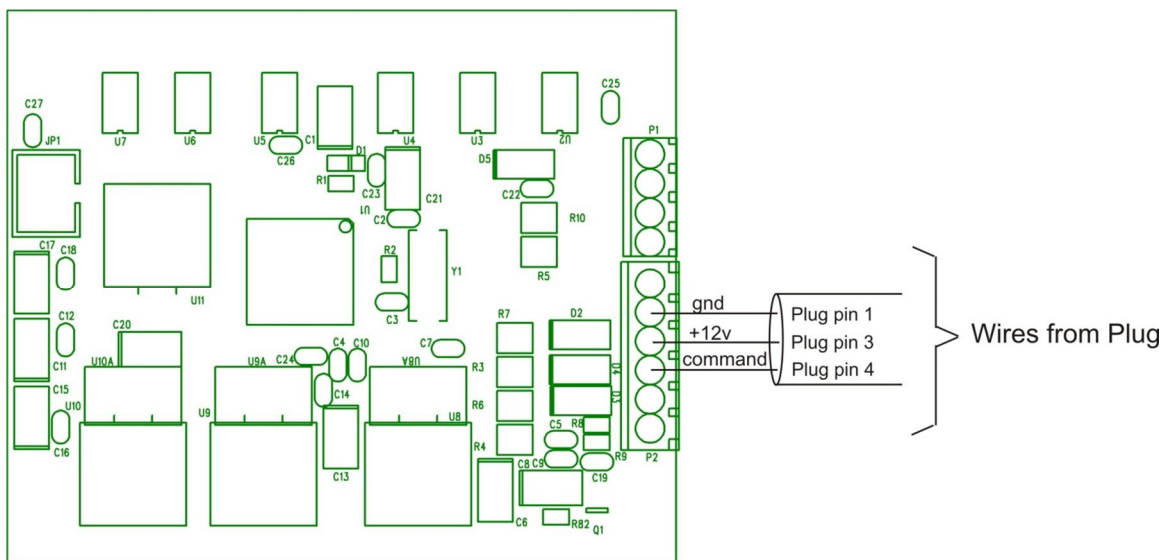

It's suggested to use two separate cables: one with 2 wires twisted and shielded for microphone

Another cable with 3 wires twisted and shielded for the display.

It's also suggested to put these two cables as separate as possible and a capacitor of 3.300uF it's recommended on the pins 19 (-) and 24 (+) of the 24 pins plug of the EP095M control unit.

## 5. GUARANTEE AND ASSISTANCE

Elettronica Progetti products are guaranteed to the original purchaser for two years from the date of purchase as shown on a valid receipt issued by the seller.

This guarantee does not affect the consumer's rights under European Directive 99/44/CE regarding certain aspects of the sale and guarantee of consumer goods; consumers should address claims under these provisions to the retailer where they purchased the goods.

This guarantee is effective in countries where European Directive 99/44/CE has been implemented. Local guarantee legislation applies in other countries.

During the guarantee period, Elettronica Progetti will repair products with defects in workmanship or materials at no charge to the customer for either labour or materials.

Travel expenses are at charge of customer.

To have work performed under guarantee, consumers must contact an Authorized Elettronica Progetti Technical Assistance Centre, or the Elettronica Progetti company at the following address:

Elettronica Progetti  
Via Traspontina, 25  
00040 Ariccia (RM) – Italy  
Tel.: +39 06 9342181  
Fax: +39 06 9344987  
Email: [info@elettronicaprogetti.com](mailto:info@elettronicaprogetti.com)

Before to send the unit to repair, operate like described:

1. Specify the type of failure
2. Specify the serial number of the control unit (see the label on the bottom )
3. Wait for the autorization to send back to the factory the unit